

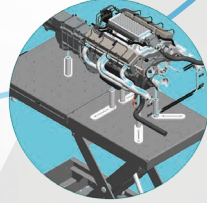

# WS LIFTER 1.4T REMOTE CONTROL

**NEW**

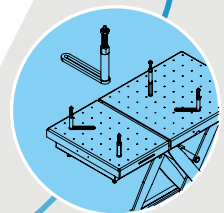
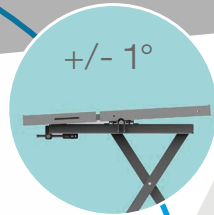
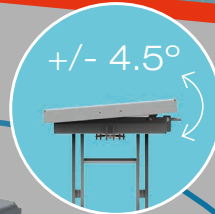

**Mobile lifter for E-car batteries, motors and gearboxes.**

WS Lifter 1.4T RC kpl.  
 pneumatic-hydraulic  
 Item No. N851025-NV

\*\*360° castors (2pcs) can be locked for straight running if required.

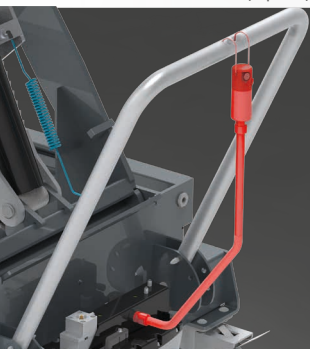

**Remote control**

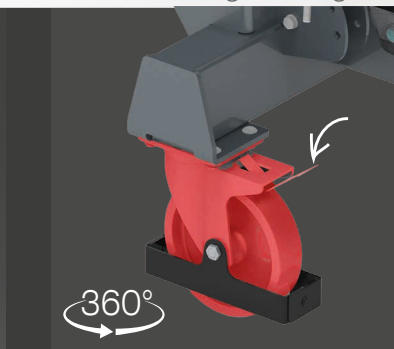

**Castors lockable\*\***



**3 Step handle**

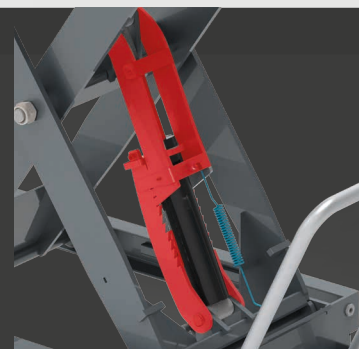

**Mechanical. fall arrest**



**NEW**

# WS LIFTER 1.4T REMOTE CONTROL

## Product features

- Lifting force 1.4 tons max.
- Mechanical **drop safety device**
- Lifting height 1,8 m max.
- Adjustable **3-step handle**
- Slope longitudinal axis +/- 1°
- Slope transverse axis +/- 4,5°
- Extendable platform 1830-2130 mm
- **Remote Control**
- Pneumatic-hydraulic drive
- 2 pcs 360° castors lockabale\*\*
- 2 pcs 360° castors with locking brake

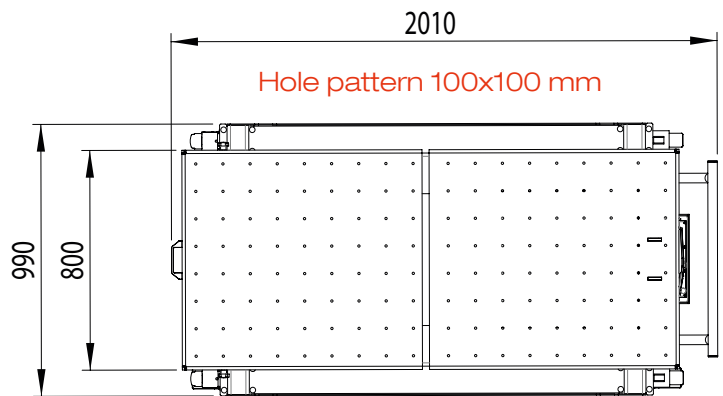

## Tech. Data

					POWER SUPPLY			
201 cm 6' 7"	99 cm 3' 3"	80 cm 2' 7"	180 cm 6'	1.400 kg 3.080 lbs	AIR	600 kg 1320 lbs	200x100x80 cm 6.5'x3'3"x32"	UNE-EN 1570-1:2012+A1

## JIGS Adapter Kit\*

Load capacity 600 kg max.

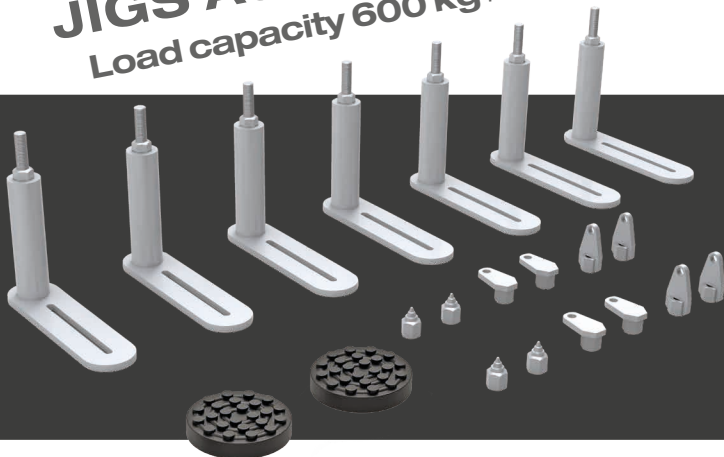

7-piece adapter kit with extension bits for different height settings of motors and gearboxes. Service and maintenance work can be carried out in a process-safe manner.

Item No. 851026NV



\* when used, the appropriate OEM workshop specifications/repair guidelines must be followed.